

# 6S 02/08/09/14 SECTIONAL TRIM FOR 6300 SERIES EXIT DEVICES

TEMPLATE: 639321  
REV. 2 09-12-24

# 4S 02/08/09/14 SECTIONAL TRIM FOR 4200 SERIES EXIT DEVICES

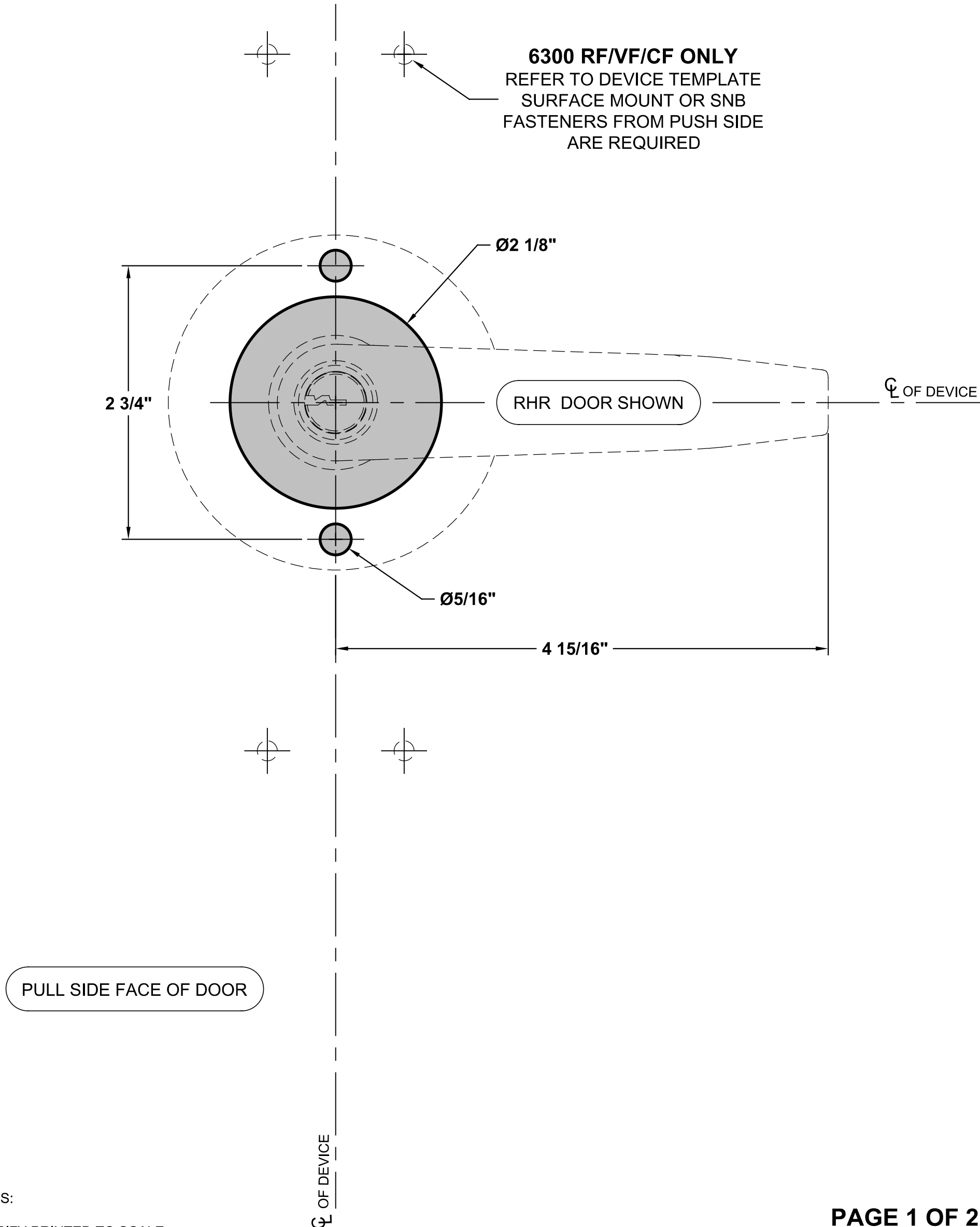

## NOTES:

1. VERIFY PRINTED TO SCALE
2. REFER TO EXIT DEVICE TEMPLATE FOR BACKSET/DEVICE CENTERLINE
3. ROSE DIAMETER: 3 3/8"  
TOTAL TRIM PROJECTION: 3 1/16"
4. MINIMUM STILE WIDTH: 4 1/2"
5. CHECK PDQ WEBSITE FOR MOST RECENT REVISION  
WWW.PDQLOCKS.COM

**PAGE 1 OF 2**



PDQ Manufacturing  
2230 Embassy Dr.  
Lancaster, PA 17603  
833-273-7832  
833-2 PDQTECH  
www.pdqlocks.com

# How to remove/replace the key in lever cylinder

## TO REMOVE CYLINDER LEVER

- A. Insert key, rotate 45° clockwise and hold
- B. Depress retainer clip with supplied pick (or other pointed tool)
- C. Pull lever from trim

## TO REMOVE CYLINDER FROM LEVER

- A. Remove cylinder stopper
- B. Slide cylinder out of lever

## TO TIME DEVICE - 08/09 FUNCTION ONLY

- A. Rotate shaded spindle CW until it stops

## TO INSTALL CYLINDER INTO LEVER

- A. Slide cylinder into lever
- B. Install cylinder stopper

## TO INSTALL CYLINDER LEVER

- A. Slide lever on to spindle up to lever retainer clip
- B. Insert key into cylinder, rotate 45° counter-clockwise and hold
- C. Push lever retainer clip into spindle then push lever passed lever retainer clip to secure lever on the spindle

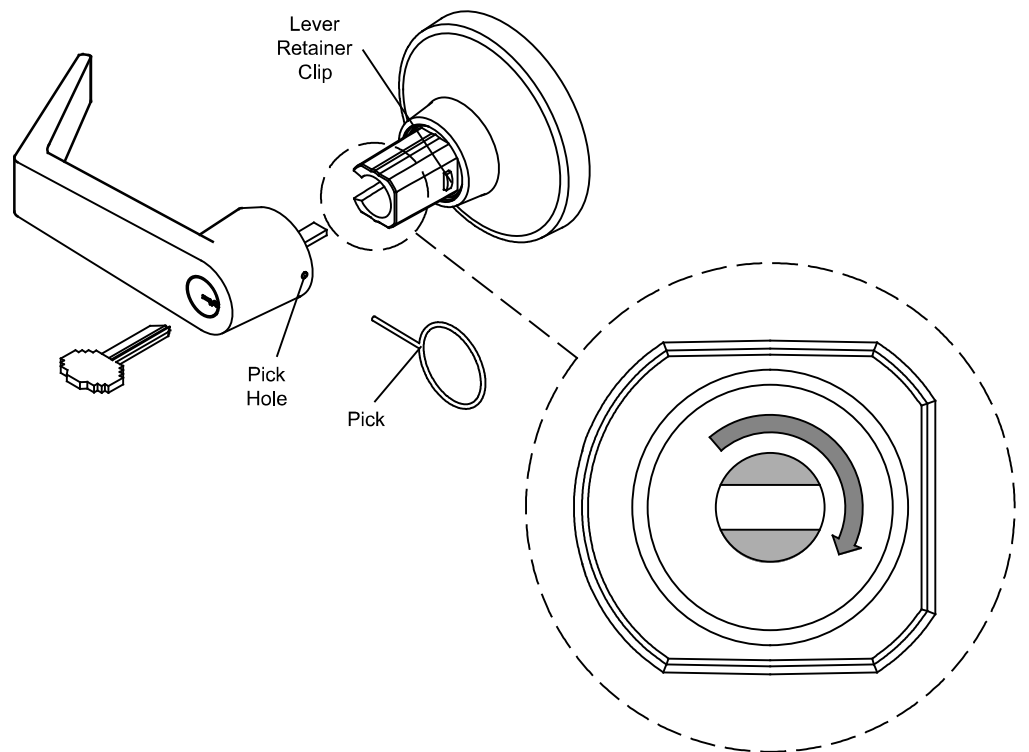

## TO REMOVE/INSTALL IC CYLINDER

- A. REMOVE  
Insert Control Key, rotate 45° clockwise then pull the core out of the lever
- B. INSTALL  
Insert Control Key, rotate 45° clockwise then push the core into the lever

## TO REMOVE/INSTALL IC LEVER

- A. REMOVE  
Remove core  
Reach into housing with fine screw driver or similar tool to move lever retainer clip toward hinge edge of door while pulling the lever from the trim
- B. INSTALL  
Remove core  
Push lever passed lever retainer clip to secure lever on the spindle

